

Micron Sonar

Ultra Compact Imaging Sonar



If the new generation of very small and low cost ROVs are to develop their full potential it is essential they are equipped with the vital tools and sensors expected on larger vehicles. The Micron Sonar incorporates the very latest surface mounted digital electronics and many software features normally found only on full sized commercial systems.

Based on experience gained from Tritech's world class range of SeaKing and SeaPrince sonars, the Micron incorporates the most advanced acoustic features and software available today. The sonar can be controlled by a customer supplied PC or laptop and it can be configured for either RS232 or RS485 protocols. The Micron has an auxiliary port to allow it to interface with other Tritech sensors.

Similar features to the SeaKing sonar in a compact housing

The Tritech Micron Sonar has set new standards in compact sonar technology. It is the smallest digital CHIRP sonar in the world. CHIRP technology dramatically improves the range resolution compared with conventional sonars - it is a feature normally associated with much larger, more expensive systems.

Benefits

- Extremely compact
- Simple to operate
- Cost effective and reliable
- Hard boot protected transducer

Features

- 750m depth rating
- True acoustic zoom
- Digital CHIRP system
- RS232 and RS485
- Target size measurement

Applications

- Small ROV obstacle avoidance
- Target recognition
- AUV guidance

Specification

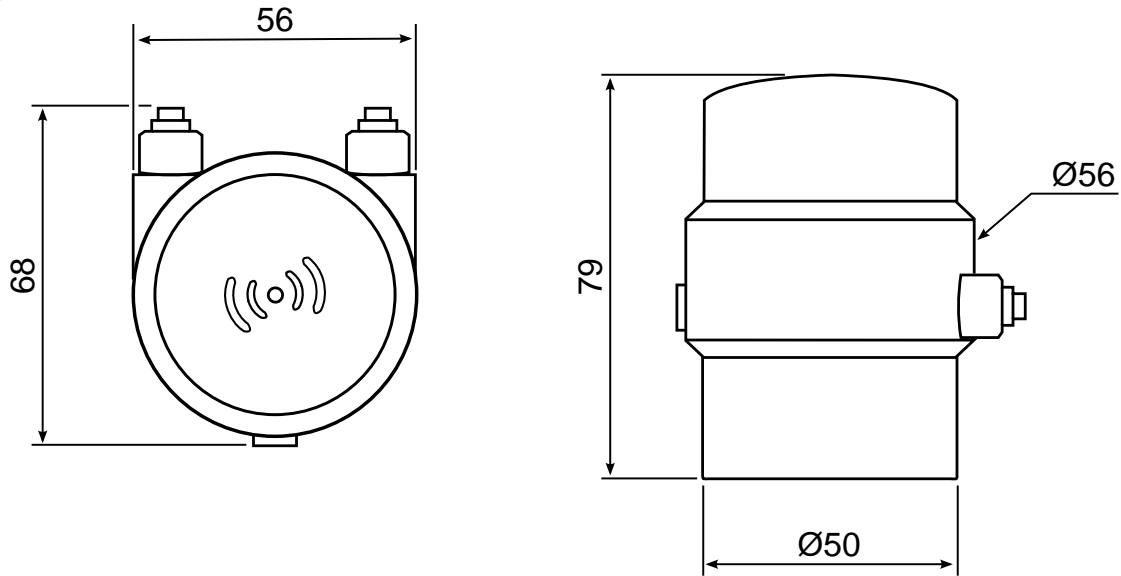

Not to scale, dimensions in mm.

Acoustic	
Operating frequency	CHIRP centred on 700kHz
Beamwidth	35° vertical, 3° horizontal
Maximum range	75m
Minimum range	0.3m
Range resolution	approximately 7.5mm (minimum)
Mechanical resolution	0.45°, 0.9°, 1.8°
Scanned sector	Variable up to 360°
Continuous 360° scan?	Yes
Sector offset mode?	Yes

Electrical, Communications and Software	
Power requirement	12 - 48V DC at 4VA (average)
Maximum cable length	1000m using RS485
Communication protocols	RS485 (twisted pair), RS232
Surface control	Computer using standard serial port, SeaHub or USB-RS232/RS485 converter
Control software	Tritech Seaneet Pro, Micron software or low-level command protocol
Software features	True acoustic zoom, instant reversal, image measurement, inverted head operations

Physical	
Weight in air	324g
Weight in water	180g
Depth rating	750m standard, 3000m optional
Temperature range	-10 to 35°C (-20 to 50°C in storage)

Specifications subject to change according to a policy of continual development.

Document: 0650-SOM-00004, Issue: 01

Marketed by:

Tritech International Ltd
 Peregrine Road, Westhill Business Park
 Westhill, Aberdeenshire, AB32 6JL
 United Kingdom
 sales@tritech.co.uk
 +44(0)1224 744 111

