

# Gemini 720im

Real-time micro multibeam imaging sonar



Operating at 720kHz, the Gemini 720im augments the successful Gemini range of imaging multibeam sonars and amalgamates many of the Gemini 720is and Gemini 720ik features into an ultra-compact unit.

The new Tritech Genesis integrated software suite communicates with the Gemini 720im, using Ethernet or Tritech's advanced Serial Multibeam Protocol (TSMP).

The auxiliary port on the sonar allows for the daisy-chaining of sensors including the Micron USBL Modem and Micron EchoSounder.

Advanced adaptive processing ensures that the most detailed image possible is generated regardless of range. This includes automatic switching between Compressed High Intensity Radar Pulse (CHIRP) and Continuous Wave (CW) modes of operation to maximize image definition.

Tritech's Genesis software suite, is supplied with the Gemini 720im and is available from the Tritech website, supporting all Tritech's sensors. There is also a Windows and Linux Software Development Kit (SDK) for the sonar to allow users to fully integrate the Gemini 720im into a customised system.

## World's smallest multibeam sonar

The Gemini 720im fuses Tritech's Gemini multibeam technology with Tritech's Micron technology to create the world's smallest multibeam imaging sonar.

Having a 90° horizontal field of view and 50m range, with an update rate up to 20Hz, the Gemini 720im brings real-time imaging to places where multibeam was never possible before.

With incredibly compact dimensions the Gemini 720im can be used in applications where size is critical. This makes the Gemini 720im ideally suited for micro ROV/AUVs in addition to applications where space is restricted or weight is critical, including diver helmet and pole mounted applications such as Search and Recovery (SAR) operations.

### Benefits

- Lightweight and compact
- 90° horizontal field of view
- Ethernet and serial communications
- Serial Auxiliary port
- Low power

### Features

- 20Hz update rate
- 300m or 750m depth rated
- Windows & Linux Software Development Kit (SDK)
- CHIRP & CW processing
- Mounting kits supporting 10deg downward tilt

### Applications

- Micro ROV/AUV navigation
- Obstacle avoidance
- Diver operations
- Aquaculture monitoring
- Vessel/Pole mount target search

# Specification

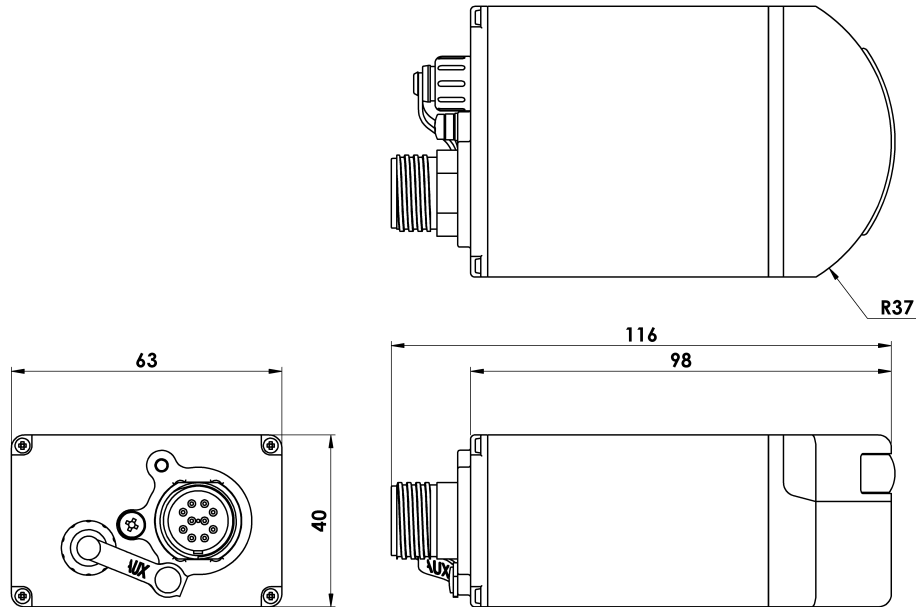

Drawing shown with Impulse MKS(W)-3L10 connector. All dimensions are in mm, not to scale.

Acoustic Specifications	
Operating frequency	720kHz
Angular resolution	2.34° acoustic, 0.7° effective
Range	0.2m to 50m
Number of beams	128
Horizontal beam width	90°
Vertical beam width	20° (±10° about horizontal axis)
Update rate (typical operation)	3 to 20Hz (range dependent)
Range resolution	8mm
Mode of operation	CW or CHIRP
Speed of Sound	Adaptive beamforming based on user specified speed of sound

Interface	
Supply voltage	12 to 48V DC
Power requirement	4.5W – 17W (7.5W average) <sup>1</sup>
Main port protocol	Ethernet (100Base-T) and/or Serial (RS232 or RS485)
Auxiliary port protocol	Serial (RS232 or RS485)
Connector type	Main: Impulse MKS(W)-3L10, Impulse MKS(W)-307 & Trittech Micron Aux: Trittech Micron

Physical specification	
Depth rating	300m or 750m
Weight in air	0.435kg
Weight in water	0.244kg
Temperature rating	-10 to +35°C (operating), -20 to +50°C (storage)

<sup>1</sup> During transmit the sonar draws approximately 17W. The range setting has negligible effect on power consumption.

Specification subject to change in line with Trittech's policy of continual product development

Marketed by:

**Trittech International Limited**  
 Peregrine Road, Westhill Business Park  
 Westhill, Aberdeenshire AB32 6JL  
 United Kingdom  
 email: [tritech-sales@moog.com](mailto:tritech-sales@moog.com)  
 Tel: +44 (0)1224 744111

